

## Spis treści / Table of contents

---

Cutting and drilling.....	p.2
Adhering and connecting LED strips.....	p.3
Attaching covers and end caps.....	p.4
Sealing the extrusion.....	p.5
Connecting extrusions using ZM connectors.....	p.6

**1.** Before cutting the extrusion with the cover, secure the cutting point with self-adhesive tape.

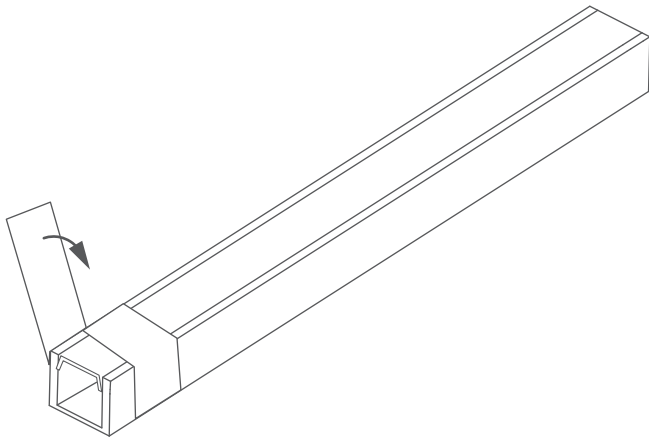

**2.** Use a mechanical saw to cut.

**NOTE!** It is recommended that the cover be cut 2 mm shorter than the extrusion to account for its thermal expansion.

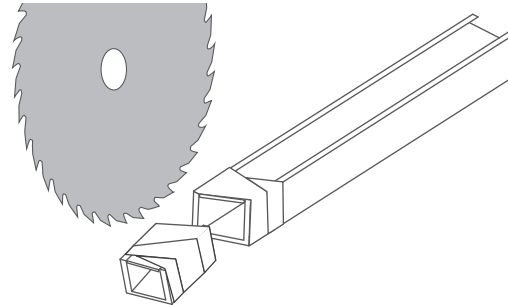

- 2mm



**NOTE!** Low precision cutting of the extrusion and cover can be done with a hand saw, however, uneven, jagged edges will remain, and the covers may break.

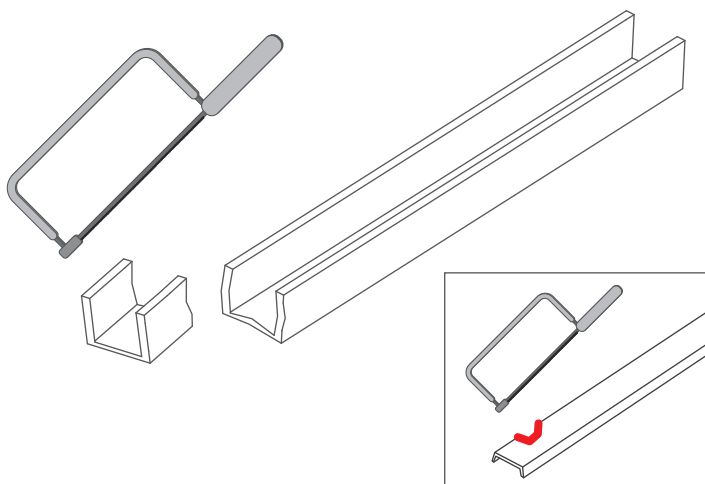

**NOTE!** For some extrusions there are dedicated end caps that require adequate shortening of the cover.

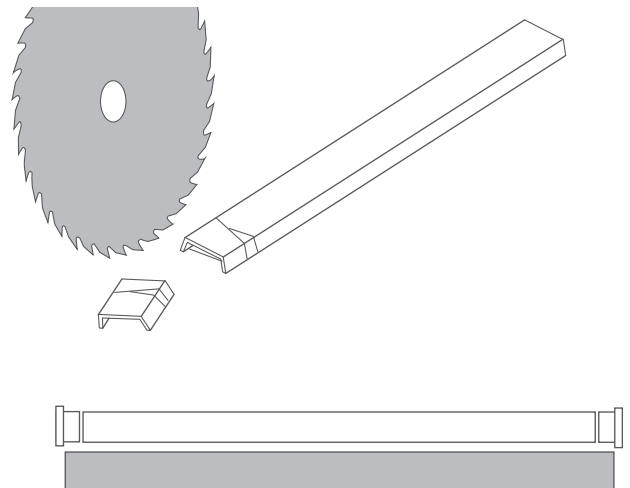

**3.** Drill a hole in the extrusion in the selected place.

**NOTE!** Make sure that there are no burrs around the hole after drilling as they can damage the LED strip or cable.

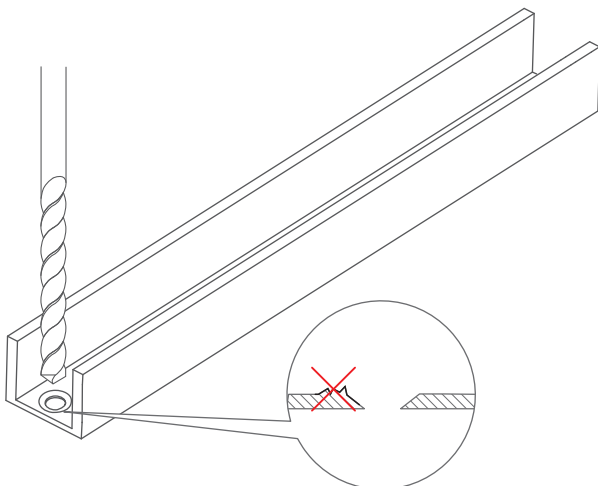

**NOTE!** Some extrusions feature one or more special grooves that make it easier to start drilling.

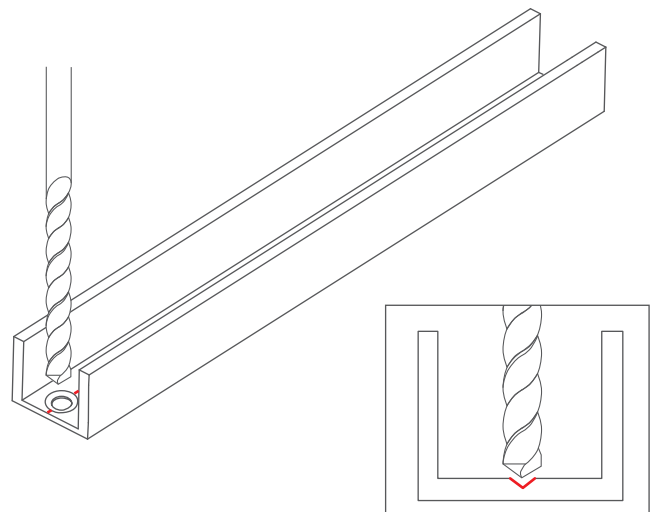

**1.** Remove the protective layer of the LED strip.

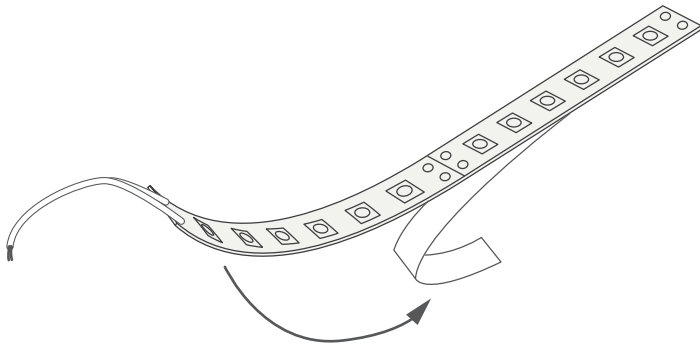

**2.** Attach the tape in the extrusion using the adhesive provided on the LED strip.

**NOTE!** The tape must not be bent or peel off the surface.

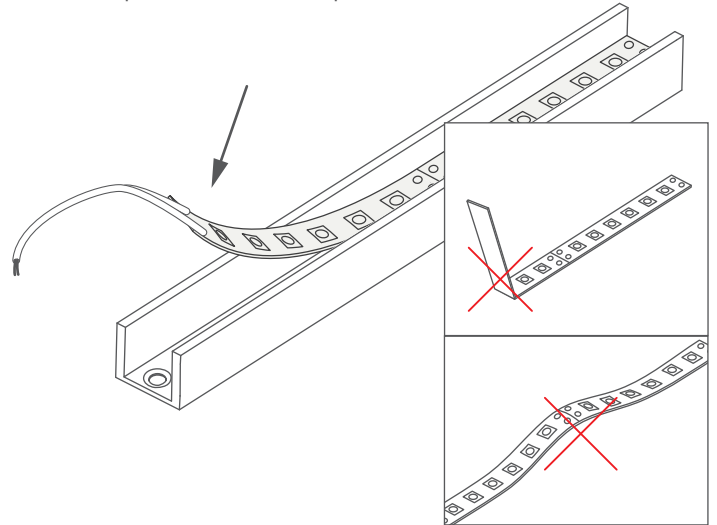

**3.** Lead the power cable through the drilled hole.

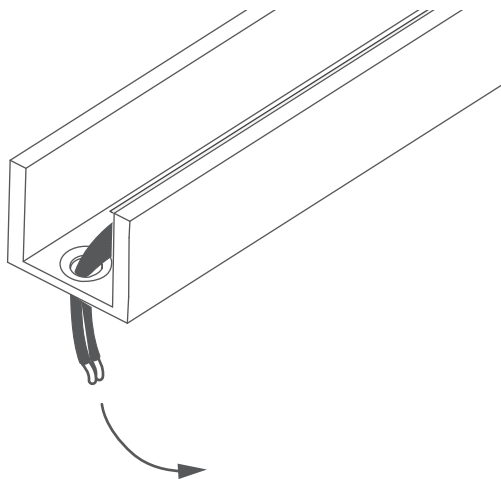

**4.** Connect the LED strips with wires by soldering.

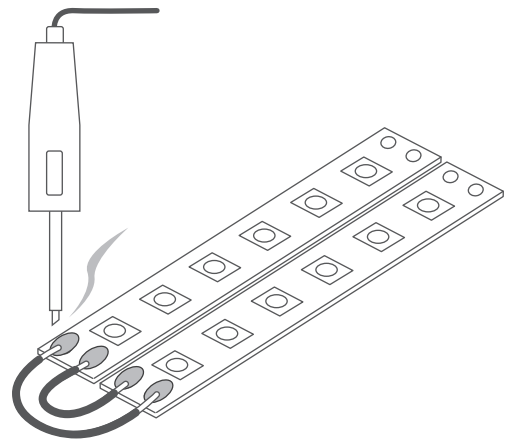

**OPTIONALLY:** The LED strips can also be connected using a system of LED strip connectors. More information at [www.klusdesign.eu](http://www.klusdesign.eu)

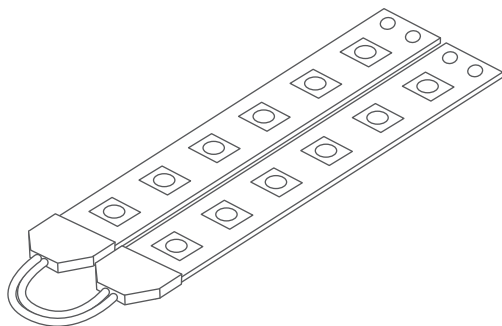

**OPTIONALLY:** The power cords can be led out from one pole of a given strip. This method is used to power suspended lighting fixtures.

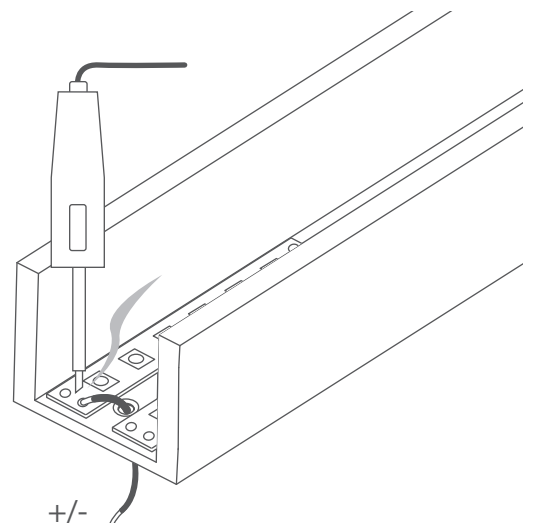

**1.** Insert the tip of the cover into the extrusion.

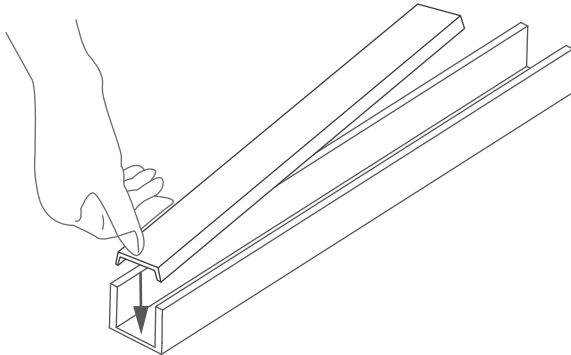

**2.** Press in the subsequent sections of the cover. Be careful not to bend or break the wings of the cover.

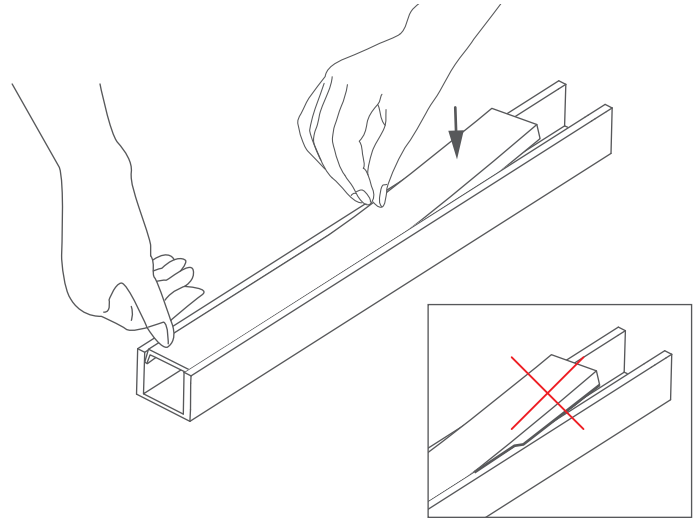

**OPTIONALLY:** Short sections, can also be inserted from the edge of the extrusion.

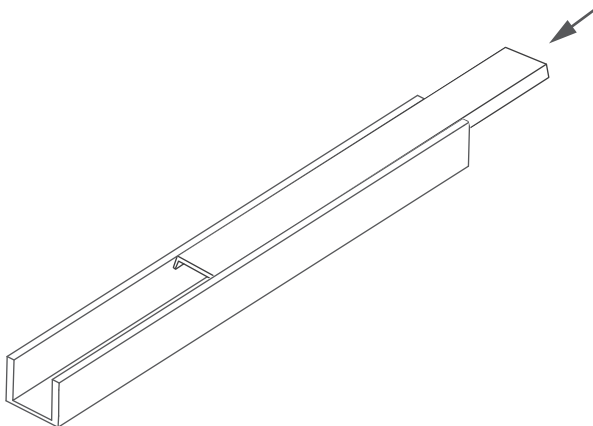

**3.** Insert an end cap into the edge of the extrusion. Individual extrusions have a shape that allows easy installation of dedicated end caps.

**NOTE!** Some end caps require an adequately shortened cover. This should be taken into account when cutting the extrusion and the cover.

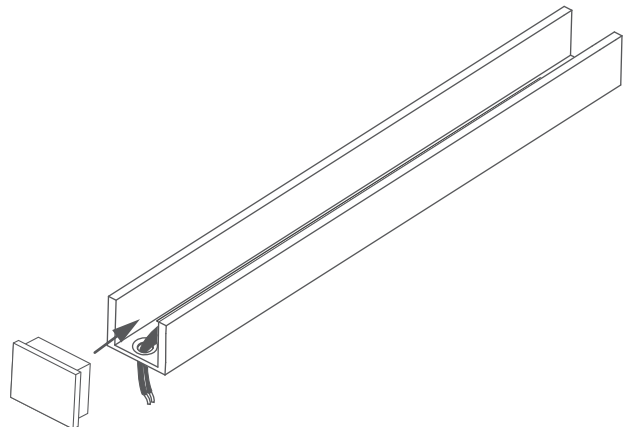

**OPTIONALLY:** The end caps can be attached to the extrusion using glue.

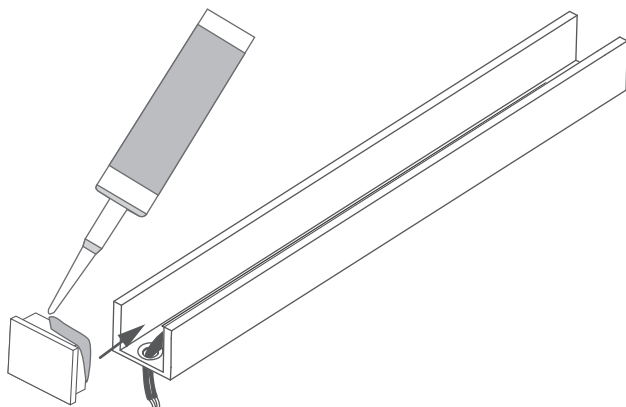

**OPTIONALLY:** Power cables can be run through the end caps in which case the extrusion does not need to be drilled through.

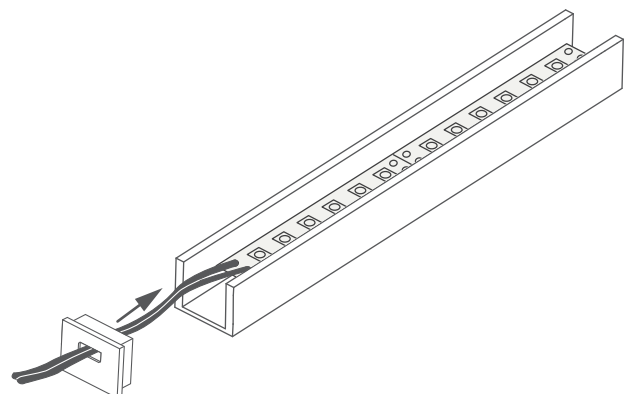

1. Clean dust and dirt from the extrusion and accessories.

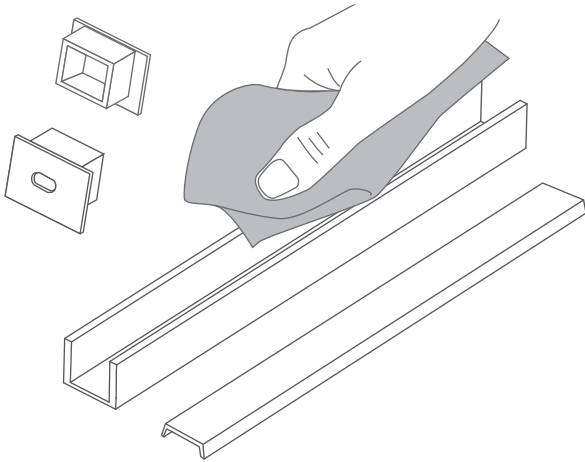

2. Attach the end caps with glue.

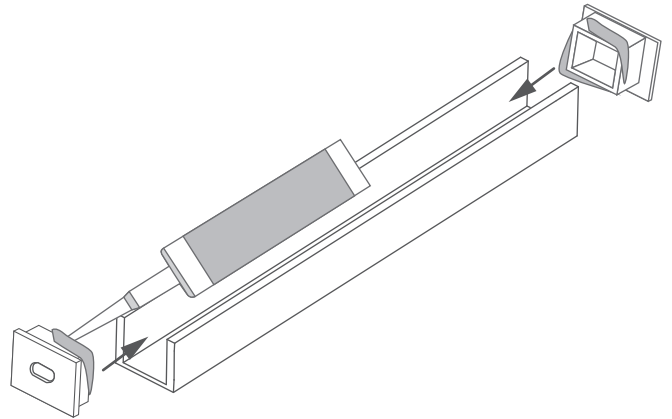

3. Apply a silicone layer to the bottom of the profile and embed the LED strip in it.

**NOTE:** The LED strip must have separate protection against moisture. We recommend a silicone sleeve or heat shrink tubing if the strip in the sleeve does not fit into the extrusion.

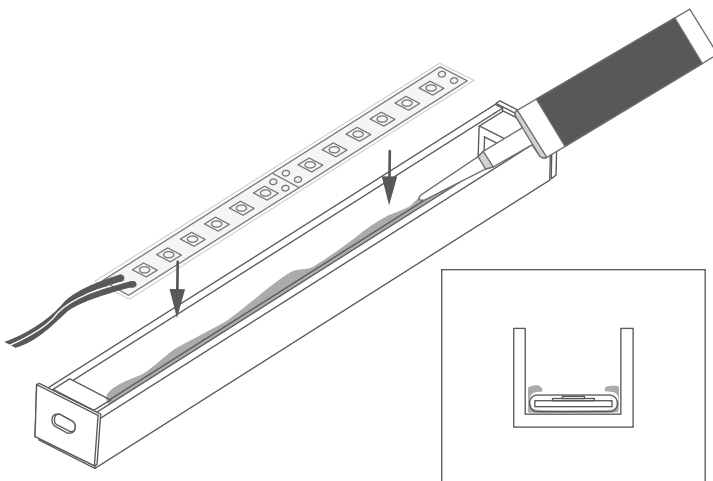

4. Apply a second layer of silicone on the extrusion walls and the end caps.

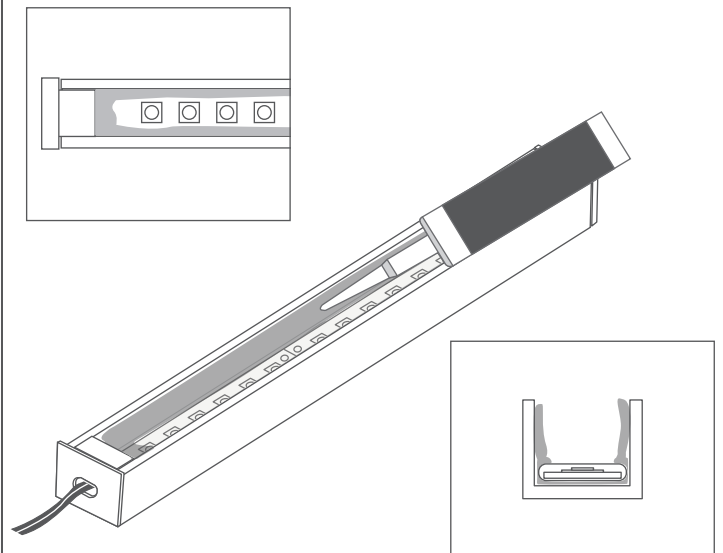

5. Remove the excess silicone with a rectangular tool (e.g. a piece of cardboard), taking care not to damage the tape. The silicone layer must be even and must not obscure the LEDs.

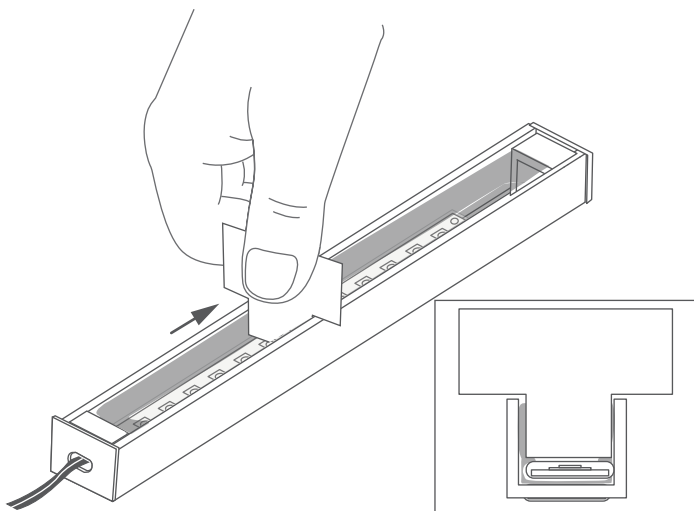

6. Insert the cover.

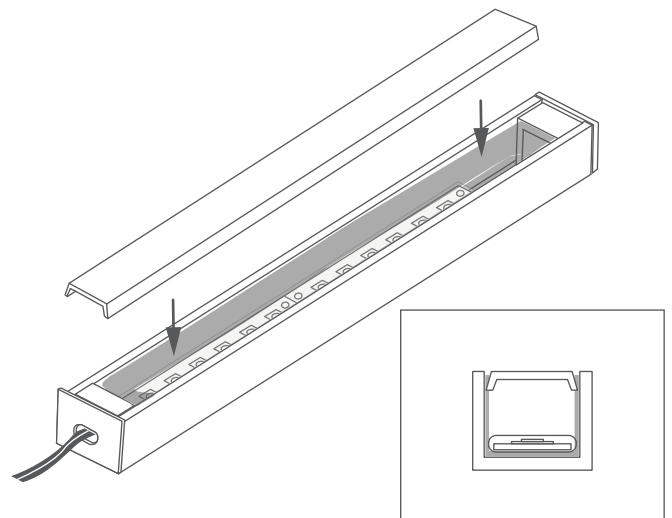

**1.** Slide the connectors into the small locks of the extrusion.

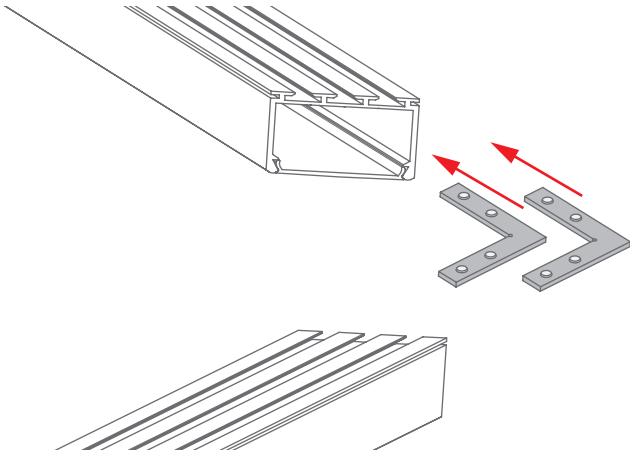

**2.** Tighten the two pressure screws in each connector with an Allen wrench.

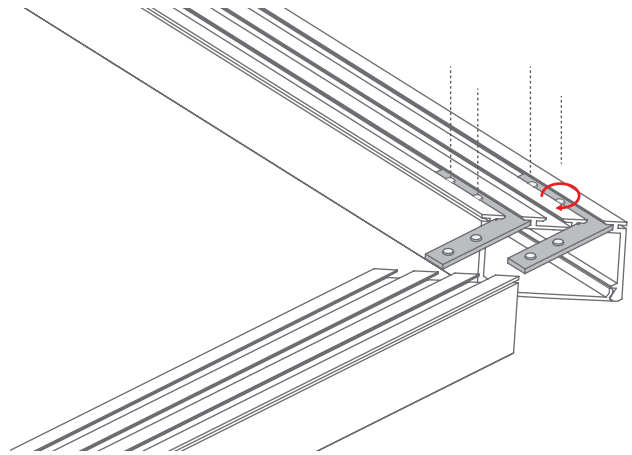

**3.** Slide the other half of the extrusion onto the connectors and tighten the pressure screws with an Allen wrench.

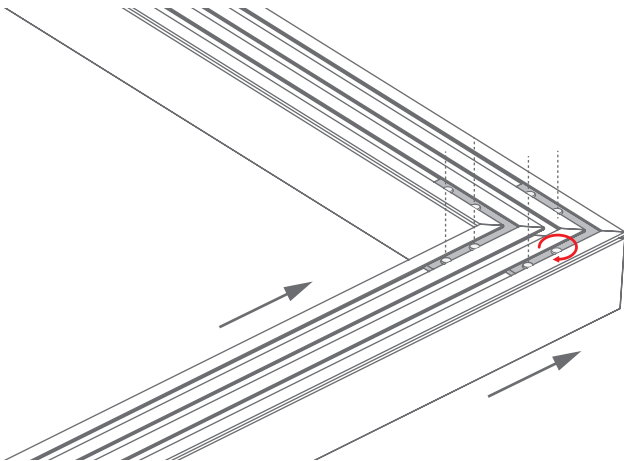

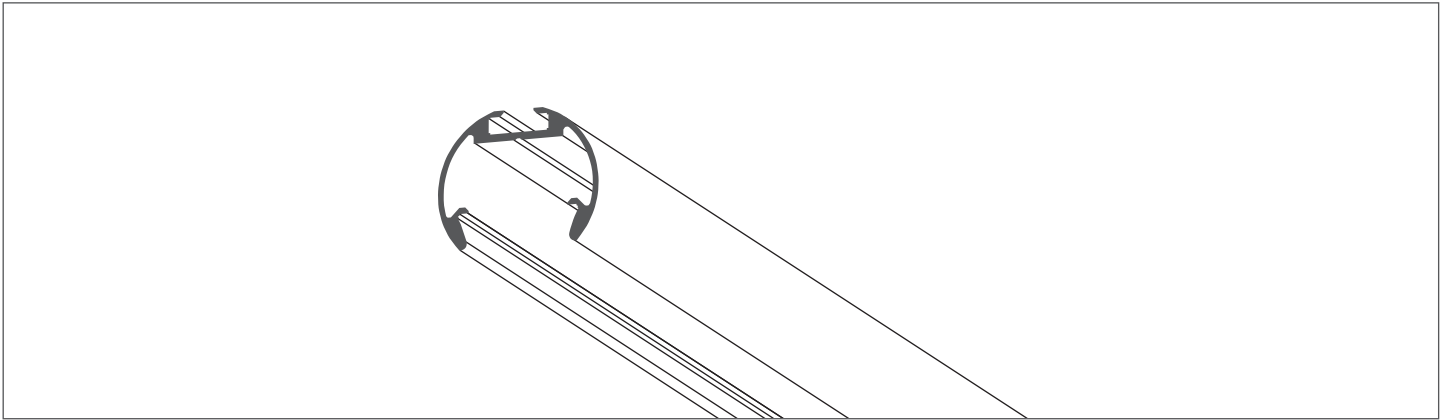

**Parts needed to mount the OLEK extrusion**



Extrusion (A)



LED strip (B)



Hanger (C)



Cover (D)



Gasket (E)

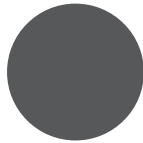

End cap (F)

**Tools needed for mounting:**

- drill
- screwdriver

**WARNING!** All LED strips should be connected to a 12 V or 24 V power supply.

**IMPORTANT:** The mounting instructions present the basic form of assembly. More methods and related accessories can be found at [www.KlusDesign.eu](http://www.KlusDesign.eu)

**1.** Drill a hole in the extrusion (A) to feed the power cable .

cross-section

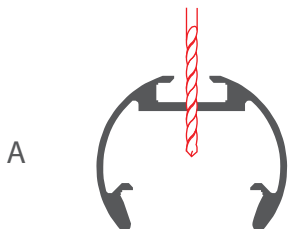

top view



**2.** Mount the LED strip (B) in the extrusion.

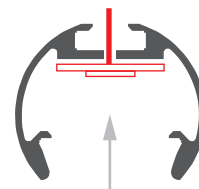

B

**3.** Suspend the extrusion using the hangers (C) and a chosen suspension system. The hanger manual can be [downloaded at www.KlusDesign.eu](http://www.KlusDesign.eu)

cross-section

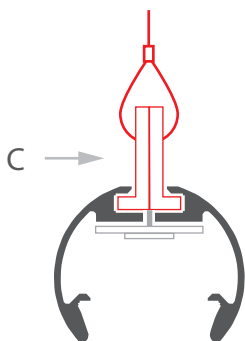

top view



**5.** Connect power to the LED strip. Insert the cover (D). Seal the end cap (F) with the gasket (E), mount the entire assembly on the top of the extrusion.

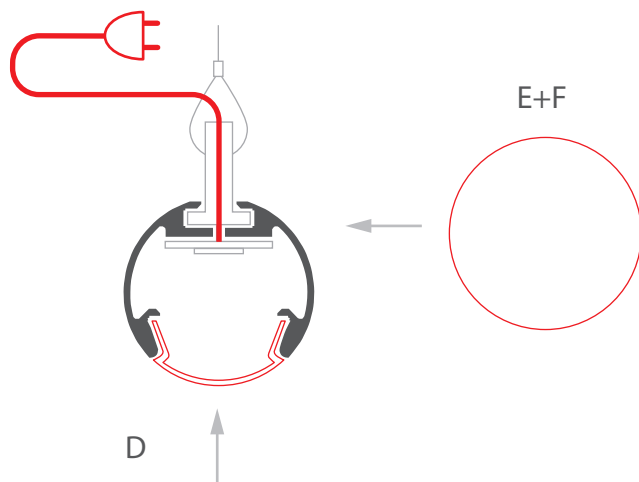

D

E+F



## PRODUCT DESCRIPTION

- Possible obtaining a circular cross-section of the lighting fixture (together with the LUK cover)
- Smooth walls ensure modern aesthetics
- Possible systemic suspension of the profile (KLUŚ accessories).

FINISH :

Silver anodized 

Fill empty fields

Product nr.	
Fixture type	
Company	
Job name	
Date	

## TECHNICAL SPECIFICATION

### Application

- for use in interior architecture in many configurations
- small lock gives possibility for constructing suspended long linear lighting fixtures
- for the construction of polygonal fittings

### Assembly

- with various suspension systems compatible with the PUSZ system or the UCHO ZM hanger

### Additional information

- possible use of electricity conductive end caps

## AVAILABLE LENGTHS

Ref. nr.	surface finish	available lengths
B8505ANODA_1	Silver anodized	1000 mm
B8505ANODA_2	Silver anodized	2000 mm
B8505ANODA_3	Silver anodized	3000 mm

TECHNICAL DRAWING

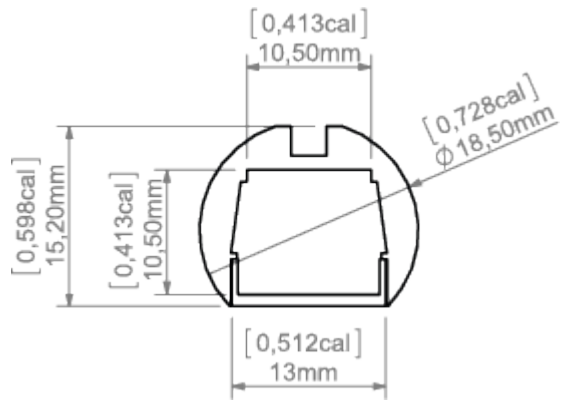

**RELATED PRODUCTS**

**COVERS**

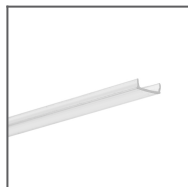

KA clear Cover  
Ref: 17036

60°

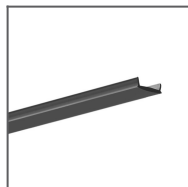

LIGER black Cover  
Ref: 17040

90°

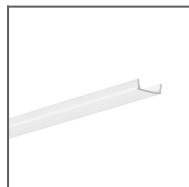

KA frosted Cover  
Ref: 17035

90°

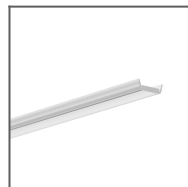

HS clear Cover  
Ref: 1370

50°

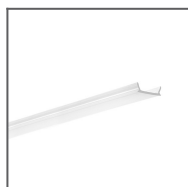

KA-PRO frosted Cover  
Ref: 17064

100°

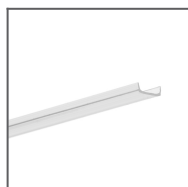

KA-COM clear Cover  
Ref: 17122

70°

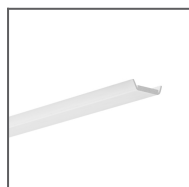

HS frosted Cover  
Ref: 1369

100°

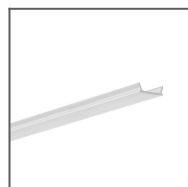

KA-PRO clear Cover  
Ref: 17065

50°

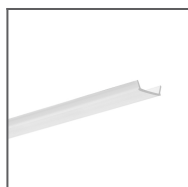

KA-COM frosted Cover  
Ref: 17121

100°

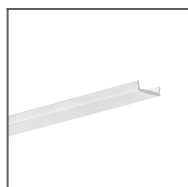

LIGER frosted Cover  
Ref: 17037

120°

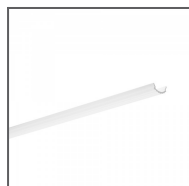
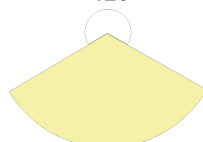

PDS-LUK frosted Cover  
Ref: 17076

120°

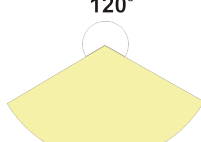

**END CAPS**



OLEK-LUK grey electricity conductive End cap  
Ref: 42620



OLEK grey electricity conductive End cap  
Ref: 42619



OLEK grey End cap  
Ref: 24203



OLEK-LUK grey End cap  
Ref: 24204

ACCESSORIES

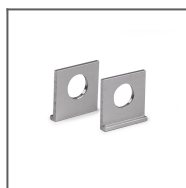

UCHO-ZM  
Fastener  
Ref: 42512



DP-PDS-O  
Fastener  
Ref: 00648



DP-ZO-PDS-O  
Fastener  
Ref: 00650



DP-ZZ-PDS-O  
Fastener  
Ref: 00655



FI-10-ZM-P  
Fastener  
Ref: 42244



FI-10-ZM-W  
Fastener  
Ref: 42242



PUSZ-LIN-ZM  
Fastener  
Ref: 42256



PUSZ-PRET-ZM  
Fastener  
Ref: 42250



W8 Fastener set  
Ref: 42606



8,8x1,2 Gland  
Ref: 00802

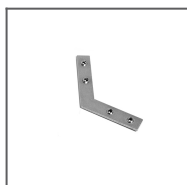

ZM-120  
Connector  
Ref: 42728

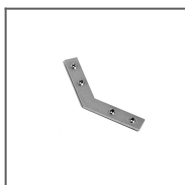

ZM-135  
Connector  
Ref: 42720

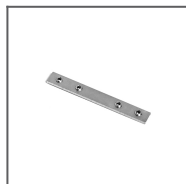

ZM-180  
Connector  
Ref: 42717

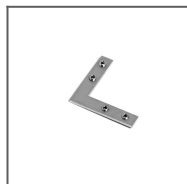

ZM-90 Connector  
Ref: 42716

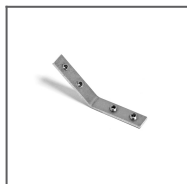

ZM-PION-135  
Connector  
Ref: 42719

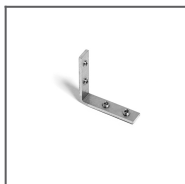

ZM-PION-90  
Connector  
Ref: 42718

MARKETING MATERIALS



Display  
P230-90106M  
Ref: 90106M



Presentation set 6  
Ref: 90125

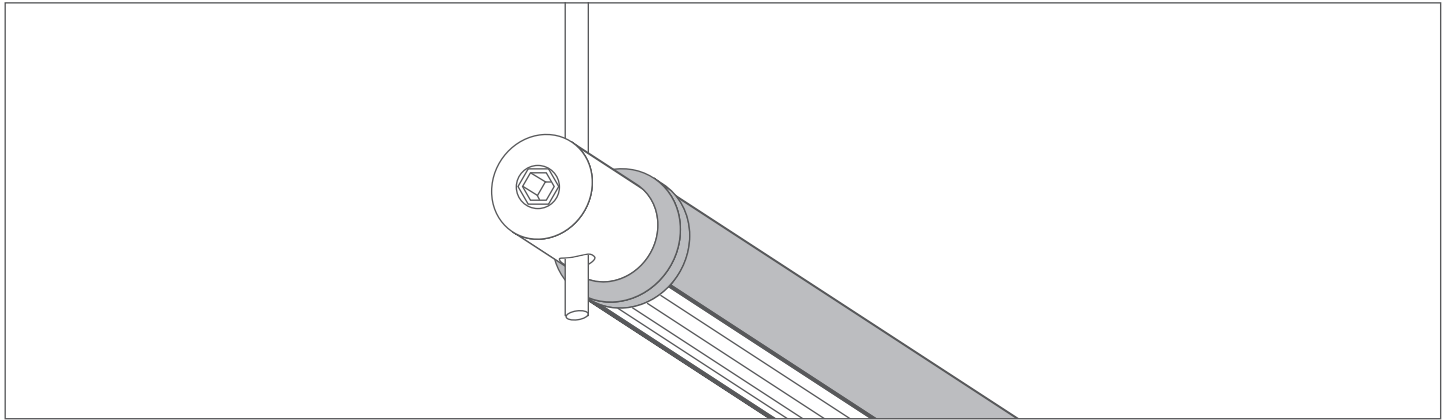

**Instruction includes methods of montage:**

**1) Rod - non-conductive  
(drop lead)**

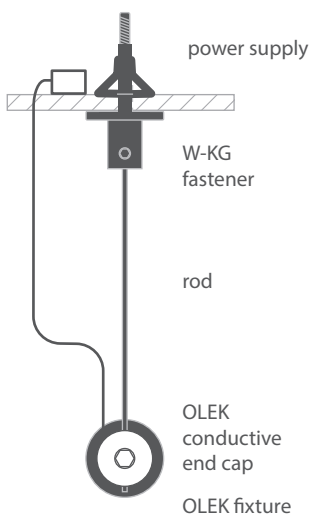

**2) Rod - conductive driven  
power supply**

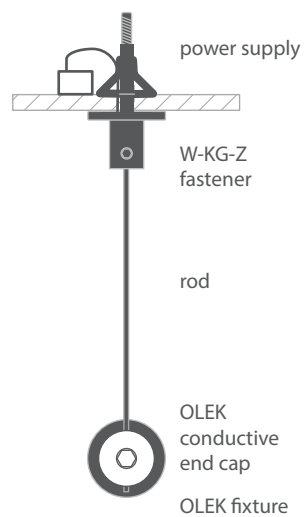

**Tools needed for mounting:**

- drill
- allen wrench
- soldering iron

**WARNING!** All LED strips should be connected to a 12 V or 24 V power supply.

**IMPORTANT:** The mounting instructions present the basic form of assembly. More methods and related accessories can be found at [www.klusdesign.eu](http://www.klusdesign.eu)

\*If fully built fixtures are ordered and received from KLUS please skip to #4

**1.** Drill a hole in the extrusion to lead the powering cable.

cross-section

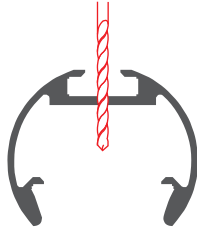

top view



**2.** Mount the LED strip in the extrusion and lead the powering cable.

cross-section

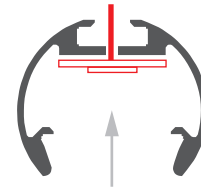

bottom view

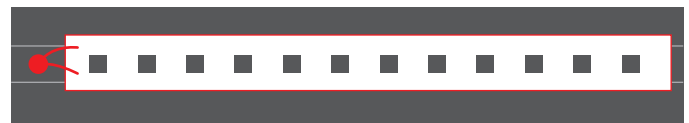

**3.** Install the cover and both conductive end caps.

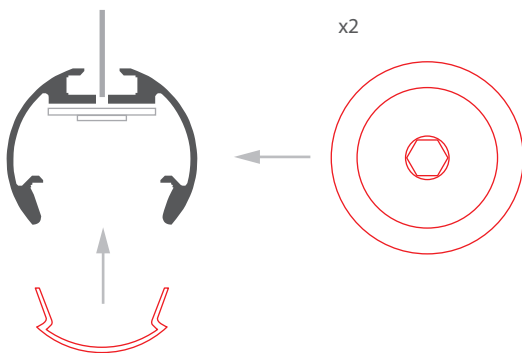

**4.** Insert the rods into the holes in the head of the conductive end caps in tighten them with an allen wrench.

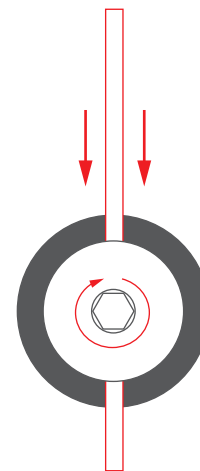

**5.** Install the W-KG ceiling fasteners. The fastener installation manual can be downloaded at [www.klusdesign.eu](http://www.klusdesign.eu). Place the power supplier next to the fastener and drill the ceiling to lead the cable to it.

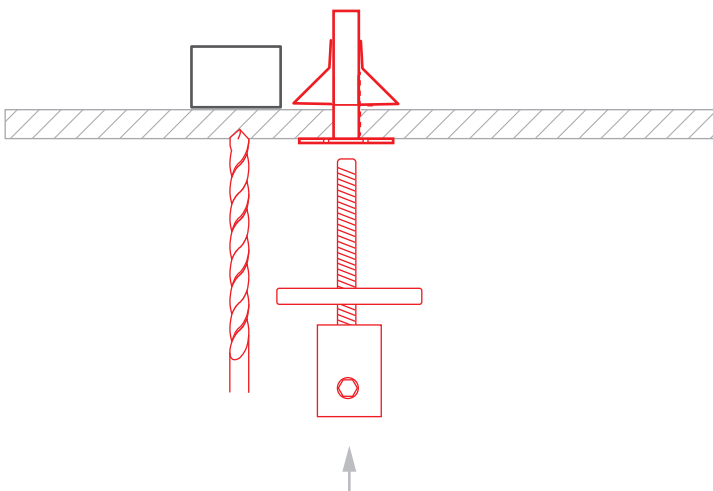

**6.** Mount the fixture with rods into the ceiling fasteners. Connect the cable to the power supplier, leading it through a pre-drilled hole in the ceiling.

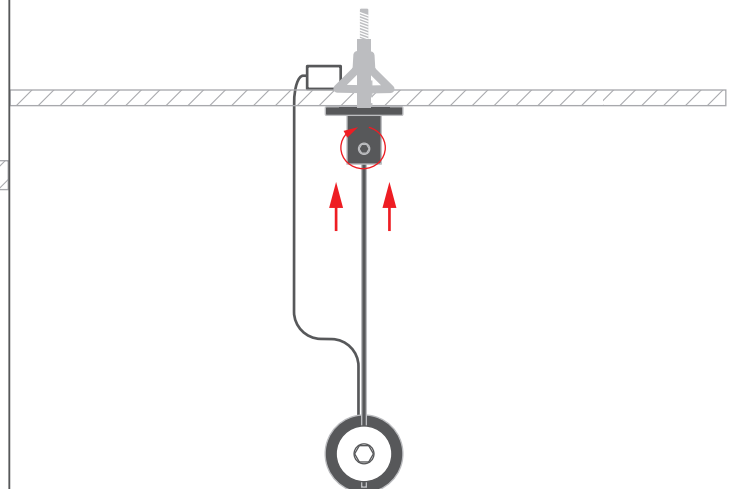

\*If fully built fixtures are ordered and received from KLUS please skip to #3

- 1.** Install the cover, LED and both the conductive end caps. The conductive plates inside the end caps must be soldered each to the separate pole on the LED strip.

cross-section

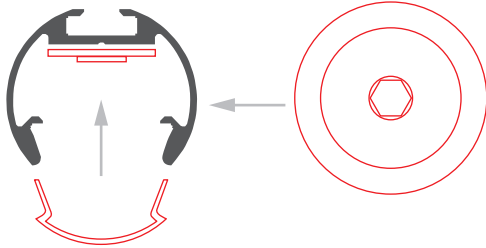

bottom view



- 2.** Insert the rods into the holes in the head of the conductive end caps in tighten them with an allen wrench.

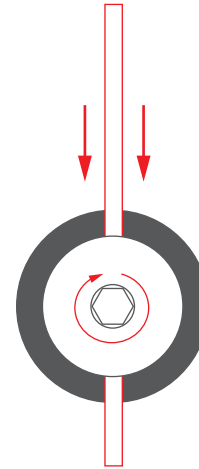

- 3.** Install the W-KG-Z ceiling fasteners. The fastener installation manual can be downloaded at [www.klusdesign.eu](http://www.klusdesign.eu). Connect the cables, each for the single power pole to the fasteners. The cables should go through a pre-drilled hole just under the masking cover of the fastener.

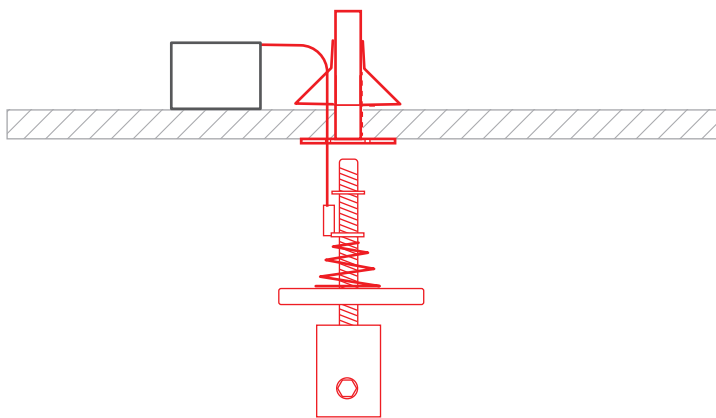

- 4.** Mount the fixture with rods into the ceiling fasteners. Mind that the power poles connected to the rods should match the ones connected to the end caps.

